

(No Model.)

2 Sheets—Sheet 1.

I. L. GRADY.

ATTACHMENT FOR WATCHMAKERS' LATHES.

No. 556,182.

Patented Mar. 10, 1896.

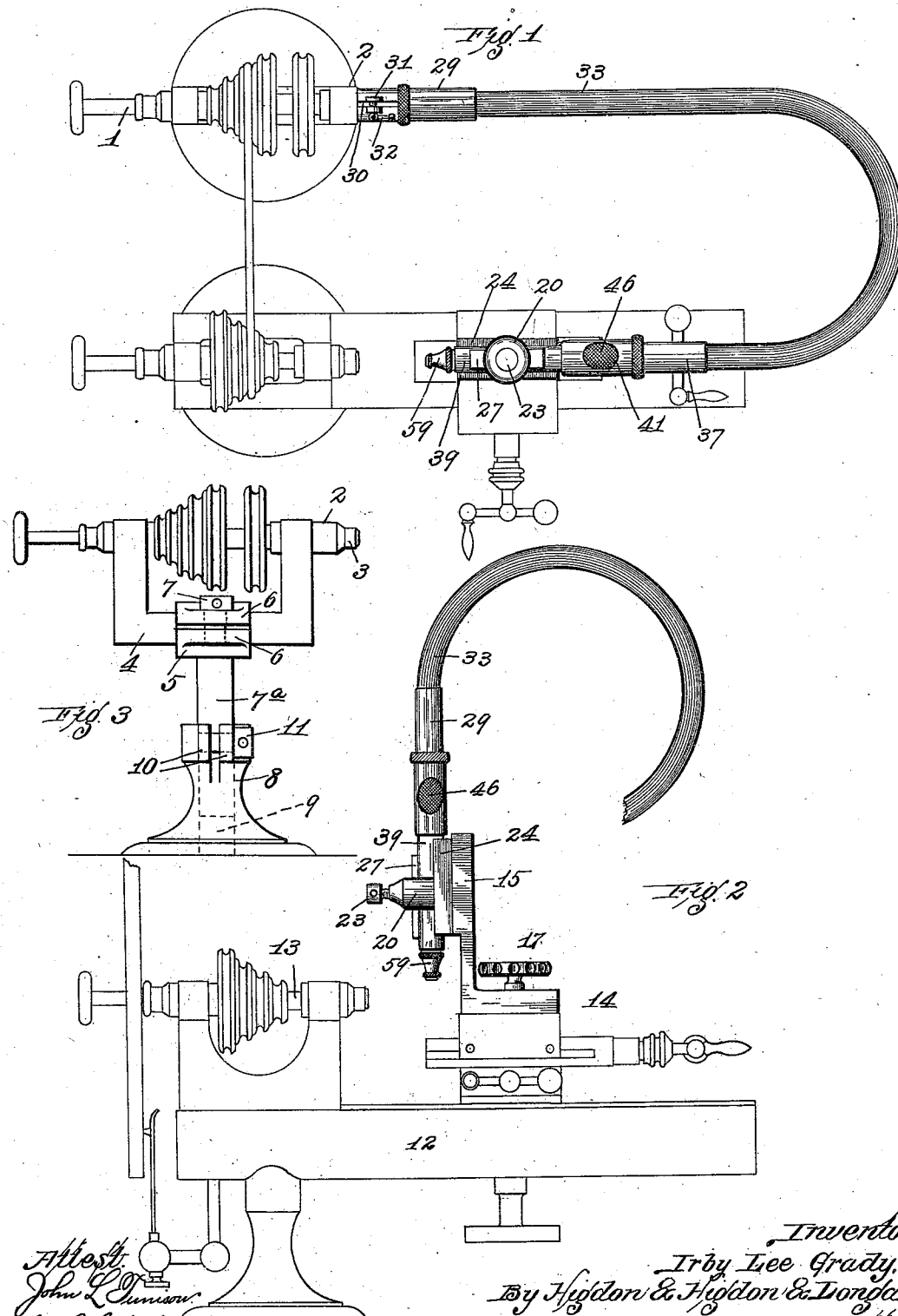

Attest:  
 John L. Dunbar  
 W. R. Smith

Inventor:  
 Irby Lee Grady,  
 by Higdon & Higdon & Donnan  
 Attys.

I. L. GRADY.

ATTACHMENT FOR WATCHMAKERS' LATHES.

No. 556,182.

Patented Mar. 10, 1896.

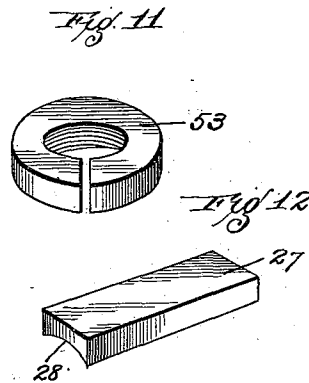
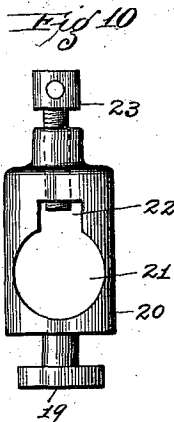
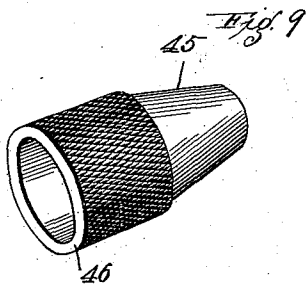
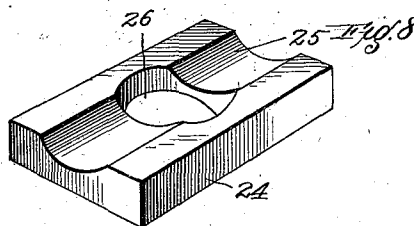
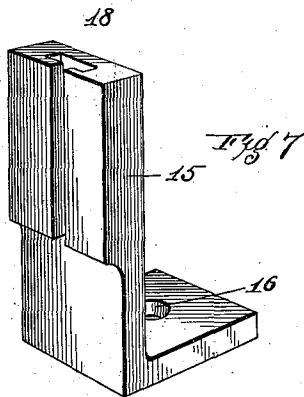
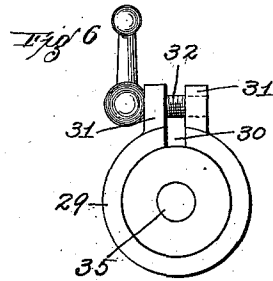
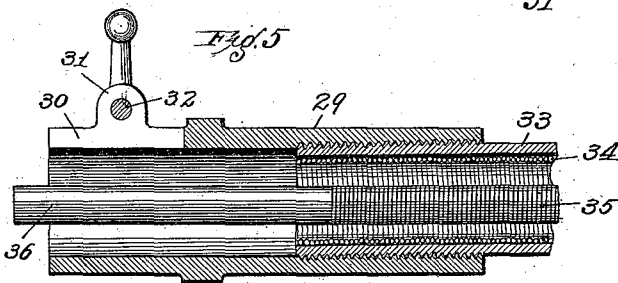
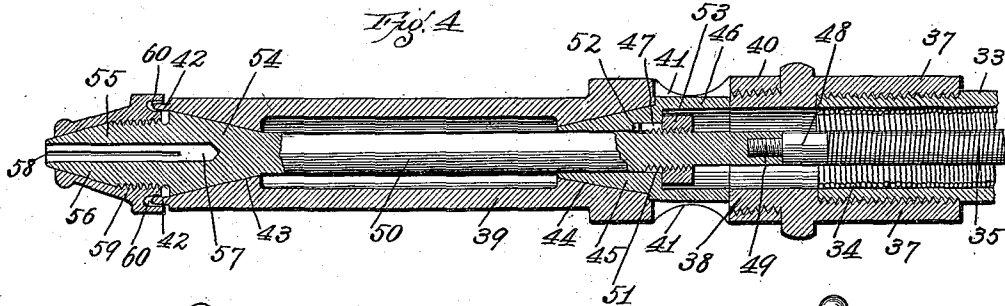

Attest  
 John L. Timison  
 M.P. Smith

Inventor  
 Irby Lee Grady  
 By Higdon & Higdon & Tongan  
 Attys

# UNITED STATES PATENT OFFICE.

IRBY LEE GRADY, OF ST. LOUIS, MISSOURI.

## ATTACHMENT FOR WATCHMAKERS' LATHES.

SPECIFICATION forming part of Letters Patent No. 556,182, dated March 10, 1896.

Application filed July 15, 1895. Serial No. 556,013. (No model.)

*To all whom it may concern:*

Be it known that I, IRBY LEE GRADY, of the city of St. Louis, State of Missouri, have invented certain new and useful Improvements in Combination-Tools, of which the following is a full, clear, and exact description, reference being had to the accompanying drawings, forming a part hereof.

My invention relates to an improved combination-tool; and it consists in the novel construction, combination and arrangement of parts hereinafter described and claimed.

In the drawings, Figure 1 is a top plan view of my improved combination-tool, the same being in an operative position upon an ordinary jeweler's lathe. Fig. 2 is a side elevation of a lathe and showing the head of my improved tool passing vertically through the tool-post. Fig. 3 is a front elevation of a vertically and laterally adjustable counter-shaft and driving-head made use of in connection with my improved tool. Fig. 4 is an enlarged longitudinal sectional view of the head of my improved tool. Fig. 5 is an enlarged longitudinal sectional view of the end of the tool that is clamped upon the driving-head on the counter-shaft of the lathe. Fig. 6 is an end elevation of the end of the tool seen in Fig. 5. Fig. 7 is a view in perspective of a bracket made use of when it is desired to hold the head of the tool in a vertical position. Fig. 8 is a view in perspective of a block used upon the slide-rest of the lathe in connection with my improved tool. Fig. 9 is a view in perspective of a cone-bearing used in the head of my improved tool. Fig. 10 is a front elevation of the tool-post of which I make use in carrying out my invention. Fig. 11 is a view in perspective of an annular nut made use of in the head of my improved tool. Fig. 12 is a view in perspective of a clamping-plate used in connection with the tool-post seen in Fig. 10.

Referring by numerals to the accompanying drawings, 1 indicates the counter-shaft, which is driven in any suitable manner, 2 the driving-head of said counter-shaft, and 3 an ordinary chuck carried by said driving-head. A frame 4, in which the counter-shaft 1 is journaled, passes through a split head 5, the same being provided with integral ears 6, through which passes a set-screw 7. Formed

integral with said head 5 and depending therefrom is a standard 7<sup>a</sup> that enters a base 8, having a vertically-arranged bore or aperture 9 therein. Integral ears 10 project from the upper end of the base 8, through which ears pass a set-screw 11. By this construction the counter-shaft is both vertically and laterally adjustable.

12 indicates the lathe-bed, 13 the spindle thereof driven from the counter-shaft in the ordinary manner, and an ordinary slide-rest 14 is arranged upon the bed 12.

15 indicates an angle-bracket, in the base of which is formed an aperture 16, through which passes a clamping-screw 17 when said angle-bracket is located upon the slide-rest. The upper end of said bracket 15 is provided with a vertically-arranged rabbeted slot 18, which is of such form and size as that it will readily receive the headed projection 19 of the tool-post 20, said tool-post being provided with a horizontally-arranged aperture 21, and formed in the upper end of said post and communicating with said aperture 21 is a rectangular cut-away portion 22. Passing from the vertically-arranged aperture in the upper end of said post is a set-screw 23, the lower end of which extends into the cut-away portion 22.

24 indicates a rectangular block having a groove 25, segmental in cross-section, extending along its entire face, and passing through the center of said block is an aperture 26 of the same size as is the tool-post. When the tool-post 20 is located upon the bracket 15, this block 24 lies directly upon the face of said bracket 15 and upon said tool-post.

27 indicates a rectangular block of such a width as that it may be located in the rectangular cut-away portion 22, and said block 27 is provided with a concave face 28, which is of the same curvature as is the aperture 21 through the tool-post. A sleeve 29 has one of its ends interiorly screw-threaded, and formed in the opposite end of said sleeve is a slot 30.

Formed integral with and projecting laterally from the face of the sleeve 29 adjacent the slot 30 are ears 31, through which passes a set-screw 32. Located in the screw-threaded end of this sleeve 29 is the end of a flexible

sheathing or tube 33, which may be of any length desired. Arranged within this flexible tube is a coil 34, and arranged within the center of said coil is a flexible shaft 35 of any ordinary construction. The end of this flexible shaft 35 within the sleeve 29 has fixed thereto a spindle 36, which projects a slight distance beyond the slotted end of said sleeve 29. The slotted end of said sleeve 29 is adapted to be clamped directly upon the driving-head of the counter-shaft, and the spindle 36 is adapted to be engaged by the chuck located within said driving-head.

Fixed to the end of the flexible tube or sheathing 33 opposite from the end to which the sleeve 29 is fixed is a sleeve 37, the same having an exteriorly-screw-threaded projecting end 38. A sleeve 39 is constructed with an interiorly-screw-threaded rear end 40, the same being located directly upon the exteriorly-screw-threaded end 38 of the sleeve 37, and formed in the rear end of said sleeve 39 is a pair of oppositely-arranged apertures 41. An annular flange 42 is formed integral with the forward edge of the sleeve 39, and oppositely-arranged conical bearings 43 and 44 are formed in each end of the sleeve 39.

Mounted for rotation in the conical bearing 44 at the rear end of the sleeve 39 is a conical sleeve 45, the same having formed integral with its rear end or base an annular sleeve 46, the exterior surface of which is milled, said sleeve 46 lying within the rear end, 40, of the sleeve 39 in the same plane with the oppositely-arranged apertures 41 in said rear end, 40. The interior diameter of this sleeve 46 is identical with the interior diameter of the forward end, 38, of the sleeve 37, while the interior diameter of the conical sleeve 45, which is uniform throughout the entire length, is somewhat smaller than is the diameter of said sleeve 46.

Formed in the body of the conical sleeve 45 and extending toward the end thereof from the shoulder between said conical sleeve 45 and the annular sleeve 46 is a slot or recess 47.

Fixed to the end of the flexible shaft 35 opposite from the end upon which the spindle 36 is fixed is a head 48, from which projects a screw-threaded pin 49. A spindle 50 has a screw-threaded bore formed in its rear end, in which this screw-threaded pin 49 is normally located. A portion of the body of this spindle 50 adjacent its rear end is screw-threaded, as indicated by 51, and a pin 52 projects from said spindle 50 adjacent said screw-threaded end, and said pin 52 is normally located within the slot or recess 47 in the conical sleeve 45.

When the spindle 50 is properly located upon the head 48 on the end of the flexible shaft 35, the screw-threads 51 are located at a point adjacent the annular shoulder formed between the sleeve 46 and conical sleeve 45, and when so located an annular nut 53 in the form of a split ring is located upon said screw-

threaded portion 51 directly against the annular shoulder.

Formed integral with the forward end of the spindle 50 is a conical head 54 of such a size as that it will readily engage in the conical bearing 43 formed in the forward end of the sleeve 39. Extending forward from this conical head 54 is an exteriorly-screw-threaded body 55 that terminates in a conical-shaped point 56. Passing diametrically through this point 56, body 55 and conical head 54 is a bore 57. The point 56 and body 55 are provided with oppositely-arranged slots 58. A conical cap 59, interiorly screw-threaded at its rear end and provided with an annular recess 60 to fit the annular flange 42 on the forward end of the sleeve 39, is arranged to be located directly upon the point 56 and body 55 of the head 54.

The operation is as follows: When it is desired to use my improved combination-tool for spindle grinding, polishing, &c., the slotted end of the sleeve 29 is clamped upon the driving-head of the counter-shaft and the spindle 36 is engaged by the chuck within said driving-head. As the counter-shaft is driven, the spindle 36, flexible shaft 35, spindle 50 and conical sleeve 45 will likewise be driven, said conical sleeve 45 and spindle 50 operating within the sleeve 39. With the rotation of the counter-shaft the spindle of the lathe will be driven, the movement of said spindle being in the direction opposite from that in which the spindle 50 moves. The proper tool being located in the bore 58 and clamped therein by tightening, the cap 59 will necessarily be rotated with the rotary movement of the flexible shaft and spindle. The tool-post 20 is arranged in the usual manner upon the slide-rest, and the block 24 is passed over said slide-rest until the same rests directly upon the top of said slide-rest. The sleeve 39 is now passed through the aperture 21 in the tool-post, and when so positioned rests directly in the concave groove 25 formed in the top of the block 24. The bearing-plate or follower 27 is now located in the cut-away portion 22 in the tool-post, the concaved under side 28 of said bearing-plate 27 engaging directly upon the top surface of the sleeve 39. The set-screw 23 is now tightened upon said bearing-plate 27 and this very effectually holds the sleeve 39 in its proper position relative to the chuck upon the lathe-spindle. When the work has been located in said chuck the lathe 39 and various parts carried thereby and operating therein can be moved in the usual manner laterally and longitudinally relative to the work that is held within the chuck, and the tool located in the head of the spindle 50 may be engaged in the desired manner upon said work. When it is desired to remove or replace a tool within the head of the spindle 50, the operator with the thumb and finger of one hand engages the milled surface of the sleeve 46, and by so doing holds

the spindle 50 and the flexible shaft 35 in a rigid position, as the pin 52 protruding from the spindle 50 engages in the slot or recess 47 formed in the conical sleeve 45. The conical cap 59 may now be loosened and removed from the point 56 of the head of the spindle 50, and the tool is free to be removed from the bore 58 in the head of said spindle 50.

To use the improved tool for gear-cutting the angle-bracket 15 is clamped on top of the slide-rest 14 by means of the clamping-screw 17. The head 19 of the tool-post 20 is engaged in the rabbeted slot 18 in said bracket 15. The block 24 is located upon the tool-post 15 and the sleeve 39 is passed through the aperture 21 in said tool-post and allowed to rest directly in the concaved groove 25 in the face of said block 24. The bearing-plate 27 is now positioned upon the sleeve 39 within the cut-away portion 22 and the set-screw 23 tightened. This holds the sleeve 39 and parts operating therein in a vertical position, and when the milling-cutter has been located in the head of the spindle 50 the various parts are in proper position to be moved toward the chuck in the lathe-spindle in which the work is located in order to allow said milling-wheel to engage with said work.

To use the tool for the purpose of engraving, polishing, drilling, and the like, the sleeve 39 is disengaged from the tool-post and held in the hand and by the same guided in the manner desired upon the work. To compensate for the wear of the head 54 and conical sleeve 45 in the conical bearings 43 and 44, I have located the split ring or nut 53 upon the screw-threaded portion 51 of the spindle 50. When it is desired to take up any wear of the parts mentioned, the operator disengages the sleeve 39 from the screw-threaded portion 38 of the sleeve 37, and, engaging the milled surface of the sleeve 46 with the thumb and finger, disengages the spindle 50 from the screw-threaded pin 49 on the head 48 of the flexible shaft 35. A small screw-driver or like tool is now inserted in the open end of the sleeve 46 and the point of said tool engaged in the slot or cut in the nut 53, and said nut may be tightened or loosened, as desired, until the proper adjustment for the conical sleeve 45 relative to the conical bearing 44 is obtained.

Various other uses for a tool constructed in accordance with the foregoing description will readily suggest themselves to persons familiar with a lathe, and said tool is very easily placed in or removed from position upon a lathe, and the same may be easily located or fixed in the various positions desired for the different classes of work to be done.

I claim—

1. In combination with a lathe, a sleeve removably fixed to the driving-head of the coun-

ter-shaft, a flexible tube or casing fixed to said sleeve, a flexible shaft arranged to be fixed in the chuck located on the counter-shaft, a sleeve having conical bearings in each end, the same being fixed to the free end of the flexible tube or casing and arranged to be held upon the slide-rest, a spindle removably fixed to the free end of the flexible shaft and operating within the sleeve, a conical sleeve carried by said spindle and operating in the rear end of the sleeve, a conical head formed integral with the forward end of the spindle, the same having a bore extending longitudinally therein, and a removable cap located upon said head.

2. A combination-tool, comprising a flexible tube or casing, a sleeve fixed to one end thereof and arranged to be clamped on the counter-shaft of a lathe, a sleeve located upon the opposite end of said flexible tube or casing and having oppositely-arranged apertures formed in its end, said sleeve being constructed with oppositely-extending conical bearings in its ends, a conical sleeve arranged to rotate in the conical bearing formed in the rear of the sleeve, a spindle passing through and operating in said sleeve, a conical head formed integral with said spindle that operates in the conical bearing formed in the end of the first-mentioned sleeve, a removable cap for said conical head, a pin projecting from said spindle that engages in the slot formed in the conical sleeve, a split ring or nut located upon said spindle within the conical sleeve, a flexible shaft removably fixed to the end of the spindle, and a spindle located upon the end of the flexible shaft that is adapted to engage in the chuck carried by the counter-shaft.

3. In a device of the class described, a sleeve having conical bearings formed in each end, a spindle passing through said sleeve, a conical head formed integral with the forward end of said spindle and engaging in the conical bearing formed at the forward end of said sleeve, a removable cap arranged upon said conical head, a conical sleeve arranged to move with said spindle within the conical bearing formed at the rear end of the sleeve, means for moving said conical sleeve longitudinally upon the spindle to compensate for the wear, a flexible shaft attached to the rear end of the spindle and driven by the counter-shaft of the lathe, and a flexible tube or casing fixed to the first-mentioned sleeve and inclosing the flexible shaft.

In testimony whereof I affix my signature in presence of two witnesses.

IRBY LEE GRADY.

Witnesses:

E. E. LONGAN,  
MAUD GRIFFIN.